

ABOVE GROUND Grease Traps (WA)

Capacity	Length	Width	Level	Height	Code
100 Litre	610	410	410	620	100GTAG
150 Litre	800	470	400	600	150GTAG
200 Litre	1220	400	400	620	200GTAG
250 Litre	1220	500	400	620	250GTAG
300 Litre	1220	620	400	620	300GTAG
400 Litre	1200	800	500	880	400GTAG
500 Litre	1300	700	700	1000	500GTAG
*600 Litre	1300	930	580	800	600GTAG
*700 Litre	1300	850	780	1100	700GTAG
*800 Litre	1600	850	720	1020	800GTAG
*900 Litre	1600	1000	670	990	900GTAG
*1000 Litre	1600	1000	750	1050	1-GTAG
*1100 Litre	1600	1000	780	1230	11-GTAG
*1500 Litre	1900	1000	930	1230	15-GTAG
*2000 Litre	2500	1000	930	1230	2-GTAG
3000 Litre	3300	1000	930	1230	3-GTAG

*Only these sizes apply to WA Water Corporation area of operation. Larger and custom units available on request.

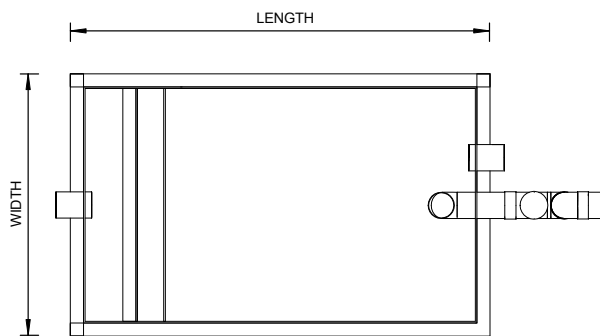

PLAN

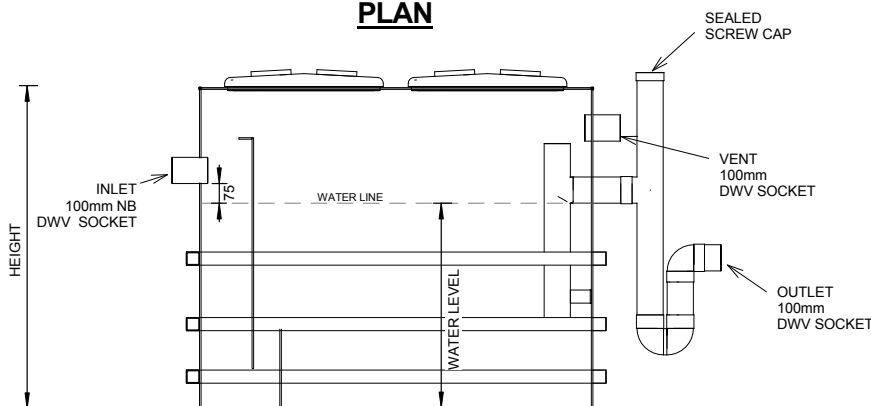

SECTION A-A

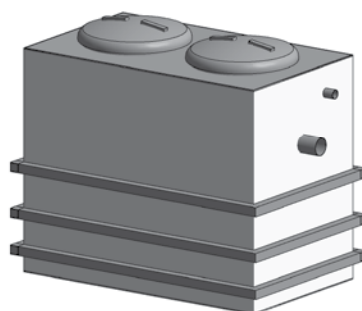

- Approved for use by the WA Water Corporation.
- Custom grease interceptors made to order.
- Fabricated from premium grade Cast PVC and Polypropylene.
- 100mm NB inlet & outlet, 50mm NB vent - unless otherwise specified.
- Sealed screw cap access covers as standard. Gas assisted hinged lids available.
- Removable galvanised steel support rails on units over 300 Litres.

Customisation

- Length width & height may be modified to suit.
- Fitting locations and sizes may be modified to suit.
- Hinged lids and "Shoebox" style lids available.
- Other modifications may be made within the guidelines of the governing water authority (Call for more information).

Other products available

- Pump Tanks
- Petrol & oil Interceptors
- Solvent Interceptors
- Mixing Tanks
- Neutralising Tanks
- Settling Tanks
- Cooling Tanks
- Straining Tanks
- Pit Liners
- Custom Pipe Fittings
- Fume Extraction & Ducting
- All Custom Fabrication



15 Deborah St Golden Square
Bendigo, 3555
P: 03 5442 8728
F: 03 5442 6137
E: info@cvplastics.com.au
W: www.cvplastics.com.au